



NIPPONIA

BS150



- Blanco
- Azul
- Rojo
- Negro
- Gris

SPARE PARTS CATALOGUE

version 19.12

E1	Crankcase Assembly	BS150
----	--------------------	-------

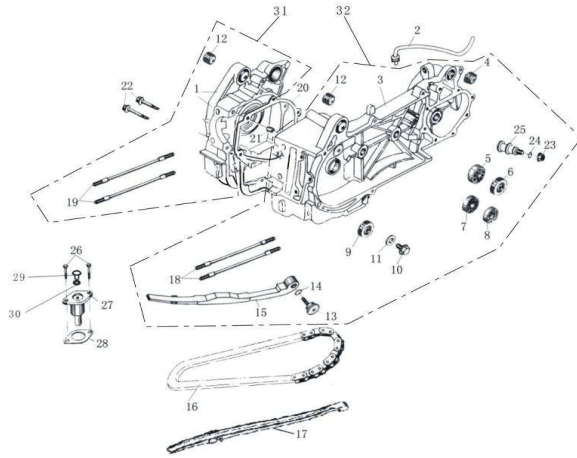

No.	Part Number	Description	Q'ty	Notes	Frame No.
1	2.20.05.03.02000	CRANKCASE, R.	1		
2	1.20.04.01.12000	TUBE, BREATH COMP.	1		
3	2.20.04.03.07000	CRANKCASE ASSY., L.	1		
4	1.20.04.01.08000	BUSH, REAR RUBBER	2		
5	1.00.01.6004-2RS	BEARING, 6004-2RS	1		
6	1.20.04.01.10000	OIL SEAL, OUTPUT SHAFT, 27X42X7	1		
7	1.00.01.6301	BEARING, 6301	1		
8	1.00.01.6002	BEARING, 6002	1		
9	1.20.04.01.13000	OIL SEAL, CRANKSHAFT, 9.8X30X5	1		
10	1.20.04.01.14000	BOLT, DRAIN, 12X1.5X14	1		
11	1.20.04.01.03000	WASHER, 12x24	1		
12	1.20.04.01.09000	BUSH, FRONT RUBBER	2		
13	1.20.13.01.01000	SCREW, CAM CHAIN TENSIONER	1		
14	1.20.13.01.02000	O-RING, 16X1.5	1		
15	1.20.13.01.05000	TENSIONER, CAM CHAIN	1		
16	1.20.13.01.04000	CHAIN, CAM	1		
17	1.20.13.01.06000	GUIDE COMP., CAM CHAIN	1		
18	1.20.04.01.04000	BOLT, STUB, M8X195.5	2		
19	1.20.05.01.01000	BOLT, STUB, M8X187.5	2		
20	1.20.04.01.05000	GASKET, R. CRANKCASE	1		
21	1.20.04.01.01000	PIN, DOWEL, Ø8X14	2		
22	1.05.01.09.0650	BOLT, M6X50	2		
23	1.05.04.01.0800	NUT, SM8	1		
24	1.20.04.01.11000	O-RING, 7.5X1.5	1		

E1	Crankcase Assembly	BS150
----	---------------------------	--------------

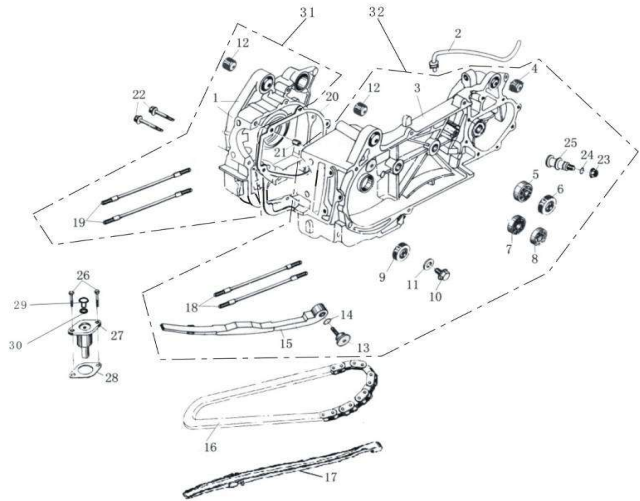

No.	Part Number	Description	Q'ty	Notes	Frame No.
25	1.20.04.01.02000	PIN, BRAKE	1		
26	1.05.01.09.0622	BOLT, M6X22	2		
27	1.20.13.01.07000	TENSIONER COMP.	1		
28	1.20.13.01.03000	GASKET, TENSIONER	1		
29	1.20.13.01.08000	SCREW, FLAT HEAD	1		
30	1.20.13.01.09000	O-RING, 9.5X1.5	1		
31	2.20.05.03.99000	R. CRANKCASE ASSY.	1		
32	2.20.04.03.99000	L. CRANKCASE ASSY.	1		

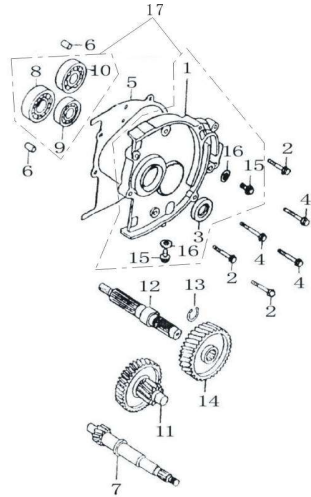

No.	Part Number	Description	Q'ty	Notes	Frame No.
1	2.20.20.01.01000	COVER, GEAR BOX	1		
2	1.05.01.09.0628	BOLT, M6X28	3		
3	1.20.20.01.08000	OIL SEAL, INPUT SHAFT, 20X32X6	1		
4	1.05.01.09.0635	BOLT, M6X35	3		
5	1.20.20.01.06000	GASKET, GEAR BOX COVER	1		
6	1.20.04.01.01000	PIN, DOWEL, Ø8x14	2		
7	1.20.20.01.02000	INPUT SHAFT, GEAR BOX	1		
8	1.00.01.6204	BEARING, 6204	1		
9	1.00.01.6202	BEARING, 6202	1		
10	1.00.01.6203	BEARING, 6203	1		
11	1.20.20.01.09000	COUNTER SHAFT COMP.	1		
12	1.20.20.01.05000	OUTPUT SHAFT, GEAR BOX (203.5)	1		
13	1.05.06.02.2000	CIRCLIP, SHAFT, 20	1		
14	1.20.20.01.03000	OUTPUT GEAR	1		
15	1.05.01.09.0812	BOLT, M8X12	2		
16	1.20.20.01.07000	WASHER	2		
17	2.20.20.01.99000	COVER ASSY., GEAR BOX	1		

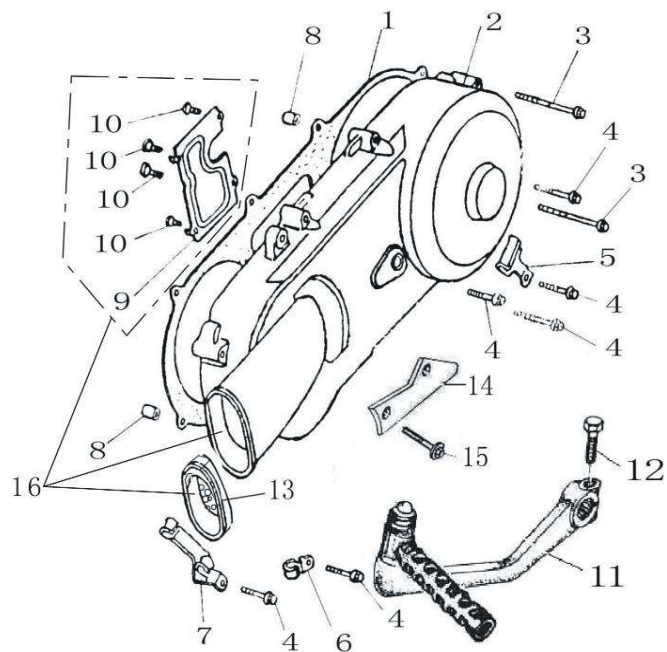

No.	Part Number	Description	Q'ty	Notes	Frame No.
1	1.20.06.03.07000	GASKET, L. CRANKCASE COVER	1	as in photo	
2	2.20.06.03.01000	L.CRANKCASE COVER	1		
3	1.05.01.09.0665	BOLT, M6X65	2		
4	1.05.01.09.0640	BOLT, M6X40	6		
5	1.20.06.01.06001	CLAMP, BRAKE CABLE	1		
6	1.20.06.01.04000	CLAMP, CARB. DRAIN TUBE	1		
7	1.20.06.01.05000	HOLDER, THROTTLE CABLE	1		
8	1.20.04.01.01000	PIN, DOWEL, Ø8x14	2		
9	1.20.06.01.03000	PLATE, AIR VENT	1		
10	1.05.02.03.4208	SCEW, TAPPING, ST4.2x8	4		
11	1.20.17.01.05000	ARM ASSY., KICK STARTER	1		
12	1.05.01.08.0622	BOLT, M6X22	1		
13	1.20.06.01.10001	PIPE, AIR INLET COMP.	1		
14	1.20.06.01.08000	BRACKET, HOLDING	1		
15	1.05.01.09.0612	BOLT, M6X12	1		
16	2.20.06.03.99000	COVER ASSY., L. CRANKCASE	1		

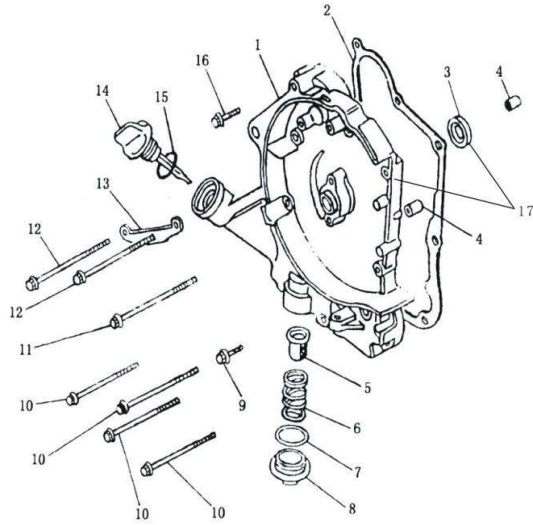

No.	Part Number	Description	Q'ty	Notes	Frame No.
1	2.20.07.01.01000	COVER, R. CRANKCASE	1		
2	1.20.07.01.06000	GASKET, R. CRANKCASE COVER	1		
3	1.20.04.01.13000	OIL SEAL, 19.8X30X5	1		
4	1.20.04.01.01000	PIN, Φ8x14	2		
5	1.20.07.01.09000	SCREEN, OIL FILTER	1		
6	1.20.07.01.03000	SPRING, OIL FILTER SCREEN	1		
7	1.20.07.01.04000	O-RING, 30.5X3	1		
8	1.20.07.01.02000	SCEW CAP, OIL FILTER SCREEN	1		
9	1.05.01.09.0632	BOLT, M6X32	1		
10	1.05.01.09.0695	BOLT, M6X95	4		
11	1.05.01.09.06100	BOLT, M6X100	1		
12	1.05.01.09.06110	BOLT, M6X110	2		
13	1.20.07.01.08000	CLAMP, TRIGGER CABLE	1		
14	1.20.07.01.05000	GAUGE, OIL LEVEL	1		
15	1.20.07.01.07000	O-RING, 18X3	1		
16	1.05.01.09.0635	BOLT, M6X35	1		
17	2.20.07.01.99000	COVER ASSY., R. CRANKCASE	1		

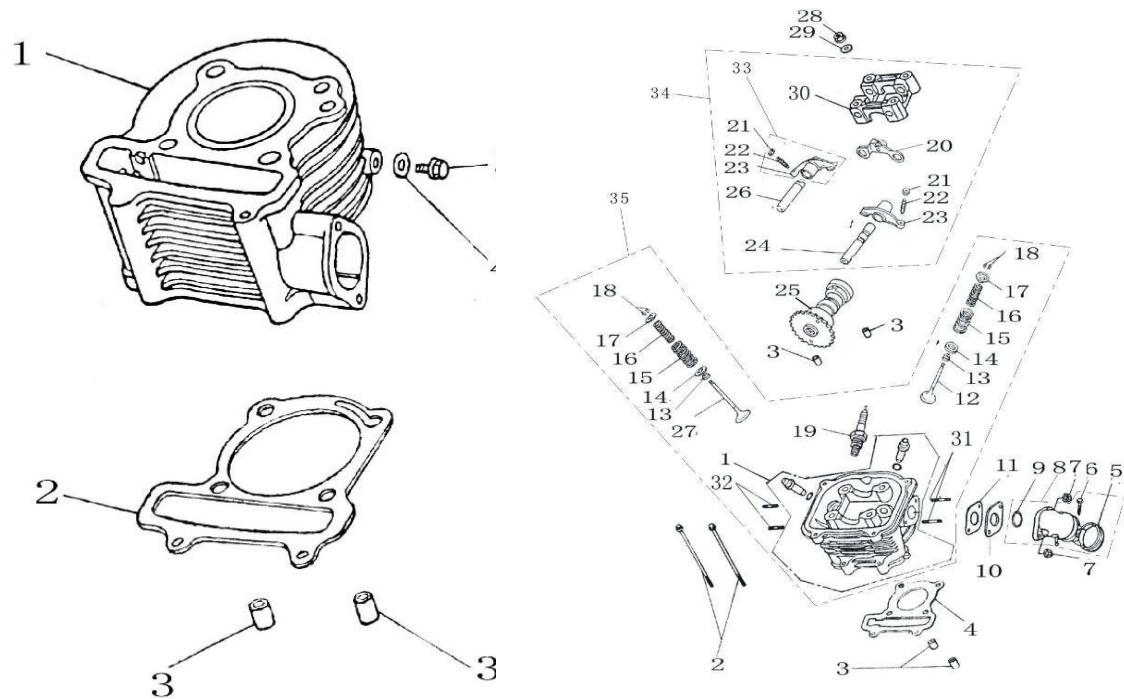

No.	Part Number	Description	Q'ty	Notes	Frame No.
1	1.20.02.03.03000	CYLINDER ASSY.	1		
2	1.20.02.03.01000	GASKET, CYLINDER	1		
3	1.20.01.01.01000	PIN, DOWEL, $\Phi 10 \times 16$	2		
4	1.20.02.01.02000	WASHER, 6x12	1		
5	1.05.01.09.0612	BOLT, M6X12	1		

E6	Cylinder Head Assembly				BS150
No.	Part Number	Description	Q'ty	Notes	Frame No.
1	2.20.01.03.13000	HEAD COMP., CYLINDER	1		
2	1.05.01.09.06100	BOLT, M6X100	2		
3	1.20.01.01.01000	PIN, DOWEL, Ø10x16	4		
4	1.20.01.03.15000	GASKET, CYLINDER HEAD	1		
5	1.20.01.01.16010	CLAMP, AIR INLET PIPE	1		
6	1.05.02.01.0425	BOLT, M4x25	1		
7	1.05.04.02.0600	NUT, M6	2		
8	1.20.01.01.16000	AIR INLET PIPE COMP.	1		
9	1.00.14.265180	O-RING, 26.5x1.8	1		
10	1.20.01.01.12000	INSULATOR	1		
11	1.20.01.01.11000	GASKET, INSULATOR	1		
12	1.20.01.03.06000	VALVE, INTAKE	1		
13	1.20.01.01.14000	SEAL, VALVE	2		
14	1.20.01.01.10000	WASHER	2		
15	1.20.01.01.09000	SPRING, VALVE OUTER	2		
16	1.20.01.01.08000	SPRING, VALVE INNER	2		
17	1.20.01.01.05000	RETAINER, VALVE SPRING	2		
18	1.20.01.01.07000	COTTER, VALVE	4		
19	1.20.01.01.17000	PLUG, SPARK	1		

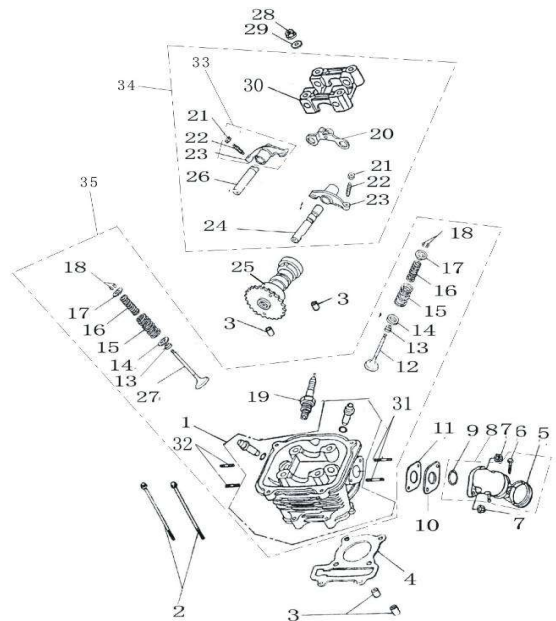

No.	Part Number	Description	Q'ty	Notes	Frame No.
20	1.20.12.01.05000	STOPPER COMP.	1		
21	1.20.12.01.04020	NUT, ADJUSTING	2		
22	1.20.12.01.04030	BOLT, ADJUSTING	2		
23	1.20.12.01.04010	ROCKER ARM	2		
24	1.20.12.01.03000	SHAFT, INTAKE ROCKER ARM	1		
25	1.20.11.01.01000	CAMSHAFT ASSY.	1		
26	1.20.12.01.02000	SHAFT, EXHAUST ROCKER ARM	1		
27	1.20.01.03.04000	VALVE, EXHAUST	1		
28	1.05.04.02.0800	NUT, M8	4		
29	1.20.04.01.06000	WASHER, 8	4		
30	2.20.12.01.01000	HOLDER, CAMSHAFT	1		
31	1.20.01.01.03000	BOLT, STUB, M6X63	2		
32	1.20.01.01.02000	BOLT, STUB, M6X32	2		
33	1.20.12.01.04000	ROCKER ARM, VALVE	2		
34	2.20.12.01.99000	SEAT ASSY., CAMSHAFT	1		
35	2.20.01.03.99000	CYLINDER HEAD ASSY.	1		

E7	Cylinder Head Cover Assembly	BS150
----	------------------------------	-------

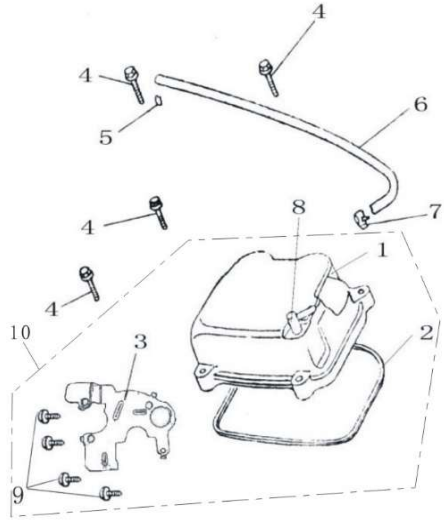

No.	Part Number	Description	Q'ty	Notes	Frame No.
1	2.20.03.01.01000	COVER, CYLINDER HEAD	1		
2	1.20.03.01.03000	GASKET, CYLINDER HEAD COVER	1		
3	1.20.03.01.02000	PLATE, CYLINDER HEAD COVER	1		
4	1.05.01.09.0622	BOLT, M6X22	4		
5	1.20.03.01.05010	CLIP, PIPE	1		
6	1.20.03.01.05000	PIPE COMP., BREATH	1		
7	1.20.03.01.05020	CLIP, PIPE	1		
8	1.20.03.01.04000	JUNCTION COMP., BREATH PIPE	1		
9	1.05.02.03.4208	SCREW, TAPPING, ST4.2X8	4		
10	2.20.03.01.99000	COVER ASSY., CYLINDER HEAD	1		

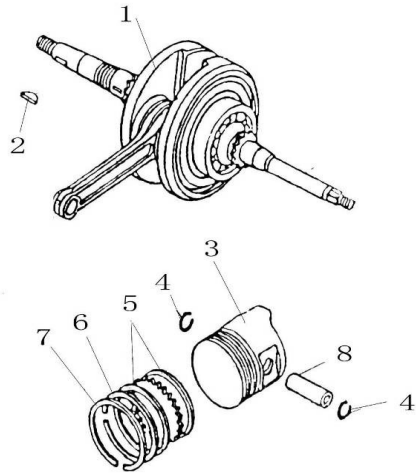

No.	Part Number	Description	Q'ty	Notes	Frame No.
1	1.20.09.01.01000	CRANKSHAFT COMP.	1		
2	1.20.09.01.01010	KEY, WOODRUFF	1		
3	1.20.10.03.01000	PISTON	1		
4	1.20.10.01.04000	CIRCLIP, PISTON PIN	2		
5	1.20.10.03.02000	RING SET, PISTON	1		
6					
7					
8	1.20.10.03.03000	PISTON PIN	1		

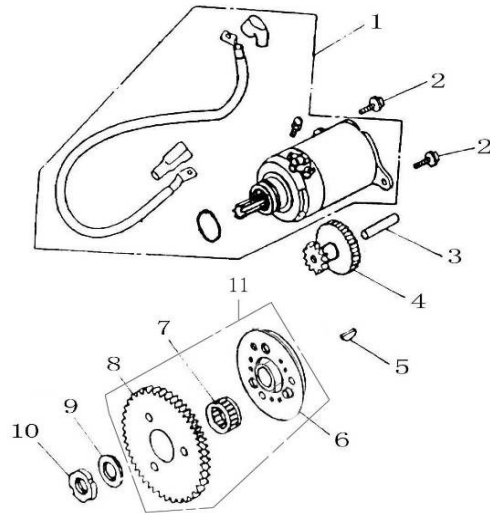

No.	Part Number	Description	Q'ty	Notes	Frame No.
1	1.20.18.01.01000	MOTOR ASSY., STARTER	1		
2	1.05.01.09.0616	BOLT, M6X16	2		
3	1.20.18.01.02000	GEAR SHAFT	1		
4	1.20.18.01.03000	GEAR, STARTER REDUCTION	1		
5	1.20.09.01.01010	KEY, WOODRUFF	1		
6	1.20.19.03.01020	CLUTCH COMP.	1		
7	1.20.19.01.01040	NEEDLE BEARING	1		
8	1.20.19.03.01030	GEAR COMP., STARTING CLUTCH	1		
9	1.20.19.01.03000	WASHER	1		
10	1.20.19.01.02000	LOCK NUT, SM22X1 L.	1		
11	1.20.19.03.01000	CLUTCH ASSY., STARTING	1		

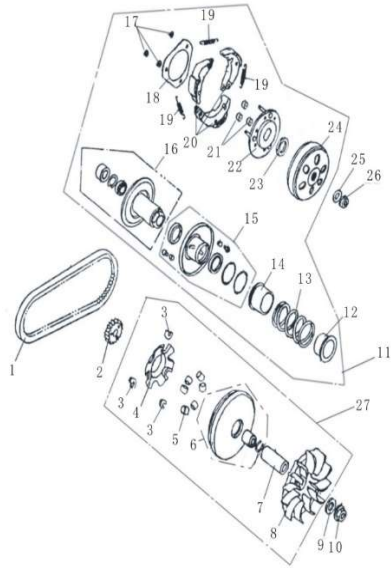

No.	Part Number	Description	Q'ty	Notes	Frame No.
1	1.20.22.03.02000	BELT, DRIVE	1		
2	1.20.17.01.04000	STARTING GEAR	1		
3	1.20.21.01.01060	PIECE, SLIDE	3		
4	1.20.21.01.01050	PLATE, RAMP	1		
5	1.20.21.01.01040	WEIGHT, ROLLER	6		
6	1.20.21.01.01030	FACE, MOVABLE DRIVE	1		
7	1.20.21.01.01020	BOSS, DRIVE FACE	1		
8	1.20.21.01.01010	FACE, DRIVE	1		
9	1.05.05.04.1200	WASHER, 12.3x29x2.5	1		
10	1.05.04.10.1213	NUT, M12x1.25 H=10	1		
11	1.20.22.01.01000	PULLEY ASSY., DRIVEN	1		
12	1.20.22.01.01070	COLLAR, SPRING	1		
13	1.20.22.01.01040	SPRING, DRIVEN FACE	1		
14	1.20.22.01.01010	COLLAR, SEAL	1		
15	1.20.22.01.01090	FACE SET, MOVING DRIVEN	1		
16	1.20.22.01.01120	FACE SET, DRIVEN	1		
17	1.05.06.04.0700	CIRCLIP, 7	3		
18	1.20.22.01.01080	PLATE, CLUTCH	1		
19	1.20.22.01.01060	SPRING, CLUTCH	3		

E10	Driving and Driven Pulley Assembly	BS150
-----	------------------------------------	-------

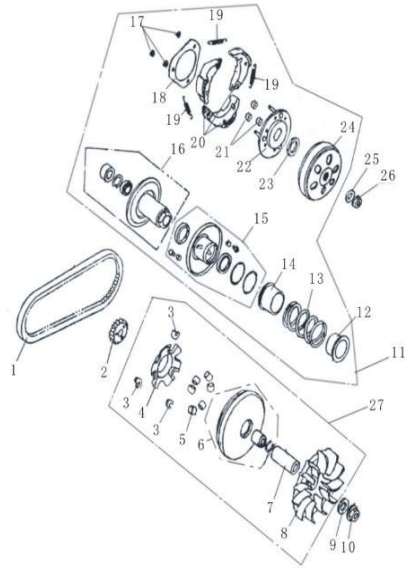

No.	Part Number	Description	Q'ty	Notes	Frame No.
20	1.20.22.01.01140	SHOE, CLUTCH	3		
21	1.20.22.01.01130	DAMPER	3		
22	1.20.22.01.01160	DRIVE PLATE COMP.	1		
23	1.20.22.01.01050	NUT	1		
24	1.20.22.01.01150	HOUSING, CLUTCH	1		
25	1.05.05.04.1200	WASHER, 12.3x29x25	1		
26	1.05.04.10.1212	NUT, M12x1.25 H=8	1		
27	1.20.21.01.01000	PULLEY ASSY., DRIVE	1		

E11	Generator Parts, Oil Pump Parts	BS150
-----	---------------------------------	-------

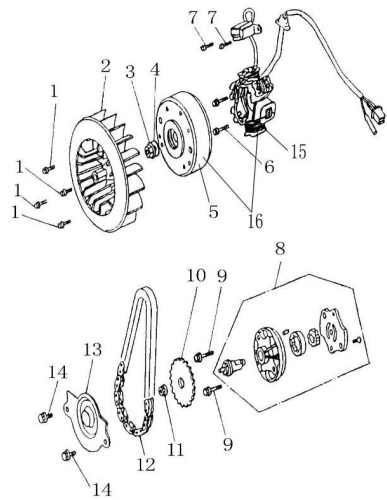

No.	Part Number	Description	Q'ty	Notes	Frame No.
1	1.05.01.09.0618	BOLT, FLANGE, M6X18	4		
2	1.20.24.01.06000	FAN COMP., COOLING	1		
3	1.05.04.10.1213	NUT, M12x1.25 H=10	1		
4	1.05.05.04.1201	WASHER, PLAIN, 12-14 HV	1		
5	1.20.16.01.01021	FLYWHEEL COMP. (DC 8 POLES)			
6	1.05.01.09.0620	BOLT, FLANGE, M6X20	2		
7	1.05.01.08.0512	BOLT, M5X12	2		
8	1.20.14.01.03000	OIL PUMP ASSY.	1		
9	1.05.01.09.0625	BOLT, M6X25	2		
10	1.20.14.01.01000	SPROCKET, OIL PUMP DRIVEN	1		
11	1.05.04.02.0600	NUT, M6	1		
12	1.20.14.01.04000	CHAIN, OIL PUMP	1		
13	1.20.14.01.02000	SEPARATOR, OIL	1		
14	1.05.01.09.0612	BOLT, M6X12	2		
15	1.20.16.01.01011	STATOR COMP. (DC 8 POLES)			
16	1.20.16.01.01001	GENERATOR ASSY. (DC 8 POLES)			

E12	Kick Starting Parts	BS150
-----	---------------------	-------

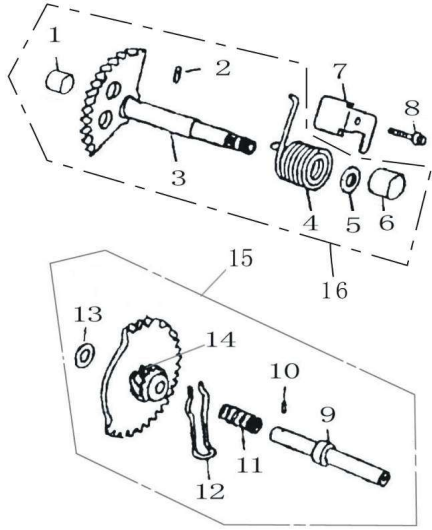

No.	Part Number	Description	Q'ty	Notes	Frame No.
1	1.20.17.01.01010	BUSH II	1		
2		PIN	1		
3	1.20.17.01.01050	SPINDLE COMP., KICK STARTER	1		
4	1.20.17.01.01020	SPRING, KICK STARTER SPINDLE	1		
5	1.20.17.01.01030	WASHER	1		
6	1.20.17.01.01040	BUSH I	1		
7	1.20.17.01.02000	PLATE, SPRING	1		
8	1.05.01.09.0614	BOLT, M6X14	1		
9	1.20.17.01.03030	SHAFT COMP., STARTER IDLE	1		
10	1.05.08.02.0308	PIN, A3x8	1		
11	1.20.17.01.03020	SPRING, COMP.RESSION	1		
12	1.20.17.01.03050	CLIP	1		
13	1.20.17.01.03040	WASHER, ADJUST	1		
14	1.20.17.01.03010	BEVEL WHEEL	1		
15	1.20.17.01.03000	WHEEL ASSY., STARTER IDLE	1		
16	1.20.17.01.01000	SPINDLE ASSY., KICK STARTER	1		

E13

Shroud Parts

BS150

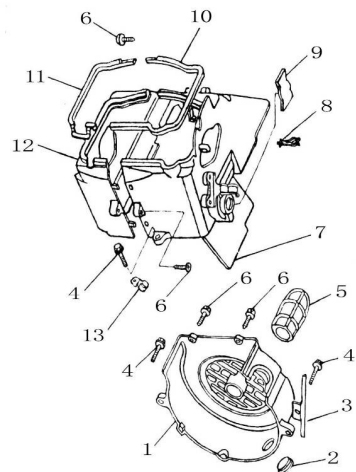

No.	Part Number	Description	Q'ty	Notes	Frame No.
1	1.20.24.01.03000	COVER COMP., FAN	1	as in photo	
2	1.20.24.01.03020	CAP, HOLE	1		
3	1.20.24.01.04000	CLAMP, CABLE	1		
4	1.05.01.09.0625	BOLT, M6X25	3		
5	1.20.24.01.03010	GUIDE TUBE , COOLING	1		
6	1.05.02.15.4816	SCREW, TAPPING, ST4.8X16-F-H	4		
7	1.20.24.01.01020	SHROUD COMP., UPPER	1		
8	1.20.24.01.01040	CLIP, HIGH TENSION CABLE	1		
9	1.20.24.01.01030	COVER, RUBBER	1		
10	1.20.24.01.01010	SEAL, UPPER SHROUD	1		
11	1.20.24.01.02020	SEAL, LOWER SHROUD	1		
12	1.20.24.01.02000	SHROUD COMP., LOWER	1		
13	1.20.24.01.05000	CLAMP, CARB. DRAIN TUBE	1		

E14	Rear Brake Assembly	BS150
-----	---------------------	-------

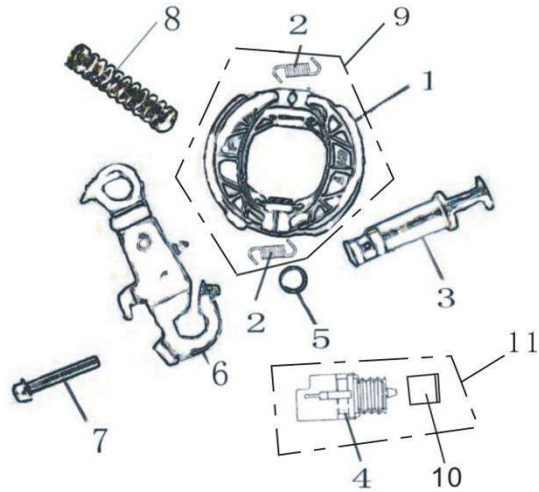

No.	Part Number	Description	Q'ty	Notes	Frame No.
1	1.20.30.03.01020	SHOES COMP., REAR BRAKE	2		
2	1.20.30.03.01010	SPRING, SHOE	2		
3	1.20.30.01.04000	CAMSHAFT, RR. BRAKE	1		
4	1.20.30.01.03020	COVER, SWING ARM, RR. BRAKE	1		
5	1.20.30.01.05000	O-RING, 11.3x1.3	1		
6	1.20.30.01.02000	SWING ARM, RR. BRAKE	1		
7	1.05.01.09.0632	BOLT, M6x32	1		
8	1.20.30.01.06000	SPRING, BRAKING	1		
9	1.20.30.03.01000	REAR BRAKE ASSY.	1		
10	1.20.30.01.03010	PLATE, SWING ARM COVER	1		
11	1.20.30.01.03000	COVER ASSY., SWING ARM	1		

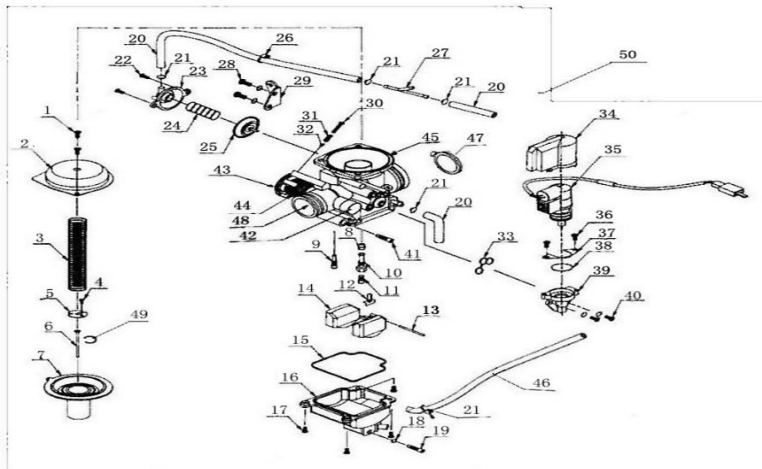

No.	Part Number	Description	Q'ty	Notes	Frame No.
1	1.20.23.01.01010	SCREW, PISTON VALVE	2		
2	1.20.23.01.01020	PLATE, PISTON VALVE	1		
3	1.20.23.01.01030	SPRING, PISTON VALVE	1		
4	1.20.23.01.01040	SCREW, MAIN NEEDLE	1		
5	1.20.23.01.01050	PLATE, MAIN NEEDLE	1		
6	1.20.23.03.01060	MAIN NEEDLE	1		
7	1.20.23.01.01070	PISTON VALVE	1		
8	1.20.23.03.01080	NOZZLE, MAIN	1		
9	1.20.23.03.01090	JET, SLOW	1		
10	1.20.23.03.01100	PIPE, MAIN JET	1		
11	1.20.23.03.01110	JET, MAIN	1		
12	1.20.23.01.01120	NEEDLE VALVE	1		
13	1.20.23.01.01130	PIN , FLOAT	1		
14	1.20.23.01.01140	FLOAT	1		
15	1.20.23.01.01150	WASHER, FUEL CUP	1		
16	1.20.23.01.01160	FUEL CUP	1		
17	1.20.23.01.01170	SCREW, FUEL CUP	4		
18	1.20.23.01.01180	O-RING	1		
19	1.20.23.01.01190	SCREW, DRAIN	1		
20	1.20.23.01.01200	FUEL PIPE	3		
21	1.20.23.01.01210	CLIP, FUEL PIPE	5		

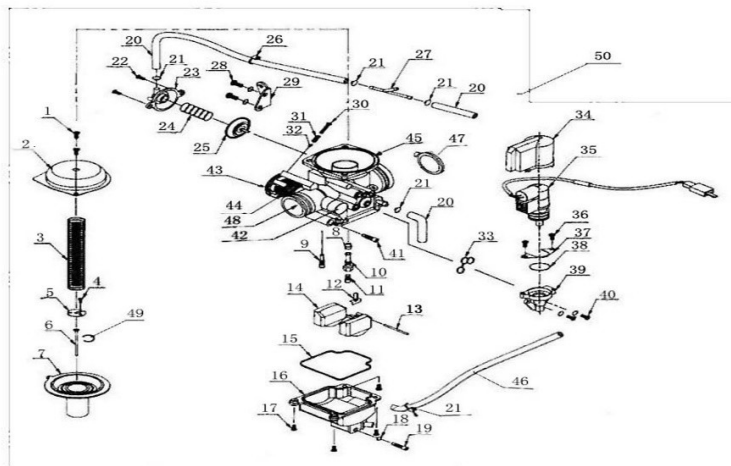

No.	Part Number	Description	Q'ty	Notes	Frame No.
22	1.20.23.01.01220	SCREW, AIR CUTOFF VALVE	2		
23	1.20.23.01.01230	COVER, AIR CUTOFF VALVE	1		
24	1.20.23.01.01240	SPRING, AIR CUTOFF VALVE	1		
25	1.20.23.01.01250	RUBBER DIAPHRAGM, AIR CUTOFF VALVE	1		
26	1.20.23.01.01260	PIPE HOLDER	1		
27	1.20.23.01.01270	THREE-WAY PIPE	1		
28	1.20.23.01.01280	SCREW, STEEL PIECE	2		
29	1.20.23.01.01290	PIECE, COPPER	1		
30	1.20.23.01.01300	SCREW, SLOW SPEED	1		
31	1.20.23.01.01310	SPRING, SLOW SPEED	1		
32	1.20.23.01.01320	RIVET, THROTTLE LEVER SEAT	1		
33	1.20.23.01.01330	RUBBER RING, AUTO CHOKE UNIT SEAT	3		
34	1.20.23.01.01340	SHELL, AUTO CHOKE UNIT	1		
35	1.20.23.01.01350	ELECTRIC AUTO CHOKE UNIT	1		
36	1.20.23.01.01360	SCREW, MOUNTING PLATE	2		
37	1.20.23.01.01370	MOUNTING PLATE	1		
38	1.20.23.01.01380	RUBBER RING	1		
39	1.20.23.01.01390	SEAT, AUTO CHOKE UNIT	1		
40	1.20.23.01.01400	SCREW, AUTO CHOKE UNIT SEAT	2		
41	1.20.23.01.01410	SCREW, SLOW-SPEED ADJUSTING	1		
42	1.20.23.01.01420	PLUG, THROTTLE LEVER	1		

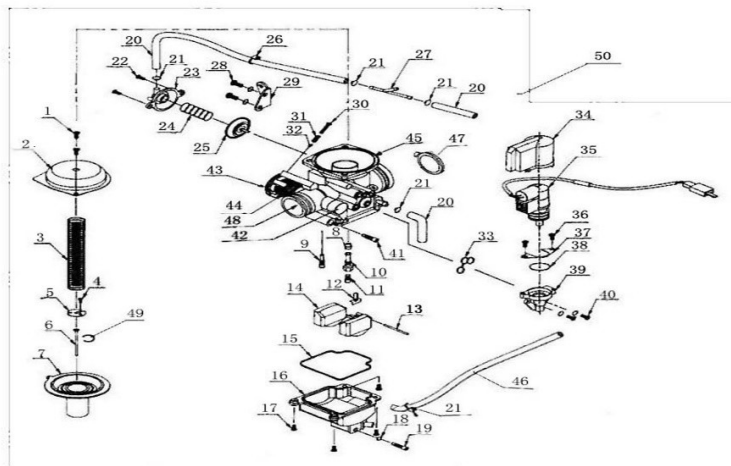

No.	Part Number	Description	Q'ty	Notes	Frame No.
43	1.20.23.01.01430	THROTTLE LEVER ASSY.	1		
44	1.20.23.01.01440	SPRING, THROTTLE LEVER	1		
45	1.20.23.03.01450	CARBURETOR ASSY.	1		
46	1.20.23.01.01460	TUBE COMP., DRAIN	1		
47	1.20.23.01.01470	COVER, DUSTPROOF	1		
48	1.20.23.01.01480	THROTTLE COMP.	1		
49	1.20.23.01.01490	CLIP	1		
50	1.20.23.03.01000	CARBURETOR ASSY. (KT)	1		