

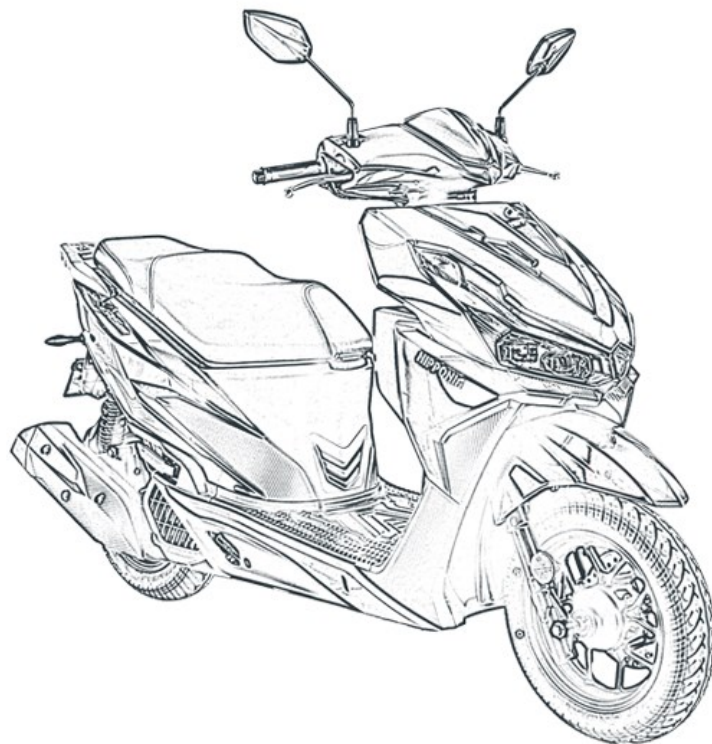

**NIPPONIA**

*Quick user guide*  
**VRS150**



**ES**

**EN**

# Guía rápida del usuario

---

## VRS150

Esta guía rápida contiene la información esencial de las partes principales de su scooter.  
Para más información descargue y lea el manual del propietario completo, disponible en [nipponiacaribe.com](http://nipponiacaribe.com)

**Nipponia S.A.**

## Vista lateral

1. Espejos
2. Intermitente delantero
3. Faro frontal
4. Freno de disco delantero
5. Tapa del VIN
6. Asiento
7. Reposapiés del pasajero
8. Portaequipajes trasero
9. Luz combinada
10. Luz de la placa
11. Reflector trasero
12. Filtro de aire
13. Caballete principal
14. Caballete lateral

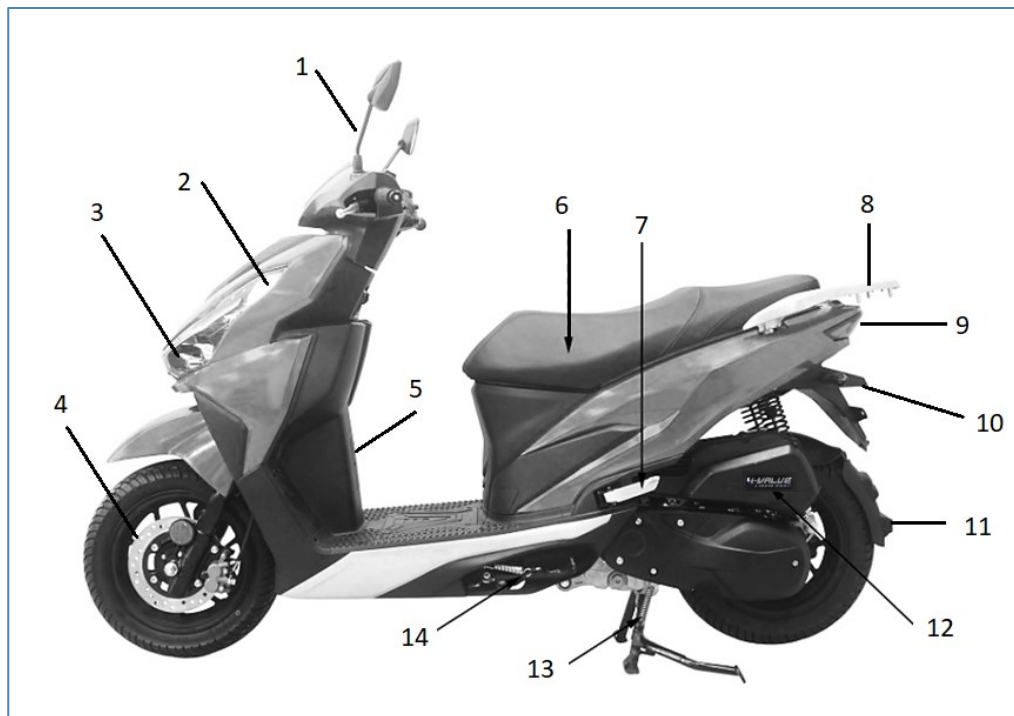

## Controles e instrumentos

1. Tablero de instrumentos
2. Puño izquierdo
3. Palanca izquierda
4. Interruptores del manubrio izquierdo
5. Toma USB
6. Gancho para bolsa
7. Interruptor principal
8. Interruptores del manubrio derecho
9. Palanca derecha
10. Puño del acelerador

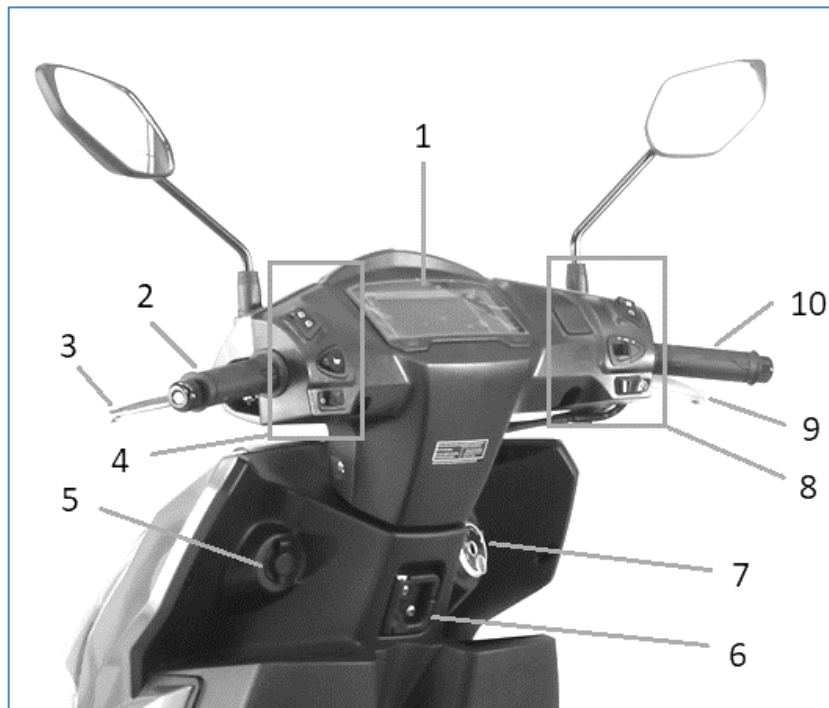

# COMPONENTES PRINCIPALES

ES

## TABLERO DE INSTRUMENTOS



1	Indicador del intermitente izquierdo
2	Visualización del reloj
3	Visualización de las revoluciones del motor
4	Luz de posición
5	Indicador del intermitente derecho

6	Indicador de luz de carretera
7	Indicación de advertencia del ABS*
8	Indicador híbrido*
9	Indicador de la alarma de temperatura del agua
10	Botón derecho (ajuste del reloj)
11	Contador de viajes (TRIP A/B) [(VIAJE A/B)]
12	Velocímetro
13	Cuentakilómetros
14	Botón izquierdo (TRIP A/B reset) [(reinicio VIAJE A/B)]
15	Indicador del nivel de combustible
16	Indicador TCS*
17	Indicador de arranque y parada*.
18	Indicación de advertencia del EFI

\*Opcional: Para países de la UE

## INTERRUPTORES DEL MANUBRIO – IZQUIERDO

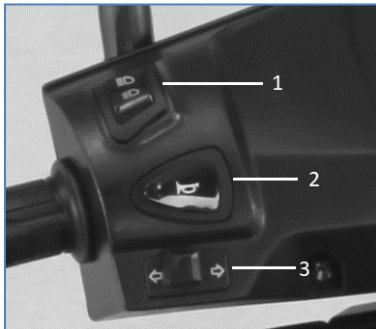

1	Interruptor de la luz de cruce / de carretera
2	Botón del claxon
3	Interruptor del intermitente

## INTERRUPTORES DEL MANUBRIO - DERECHO

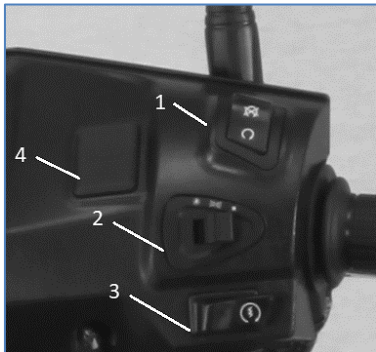

1	Interruptor de apagado de emergencia
2	Interruptor de luces
3	Interruptor de encendido
4	Botón blanco

## INTERRUPTOR PRINCIPAL

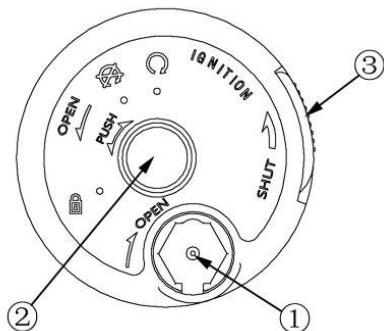

## Instalación de la batería

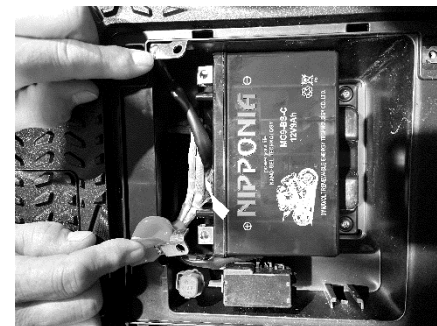

1. Ranura del interruptor de encendido
2. Tapa de la bocallave
3. Botón

1. ON [CONEXIÓN]
2. OFF [DESCONEXIÓN]
3. BLOQUEO de la dirección

Coloque la batería según la foto de arriba.

# Quick user guide

---

## VRS150

This quick guide contains the essential information of the main parts of your scooter.  
For more information download and read the complete Owner's manual available at [nipponiacaribe.com](http://nipponiacaribe.com)

**Nipponia S.A.**



## Side view

- 15. Mirrors
- 16. Front turn signal light
- 17. Headlight
- 18. Front disc brake
- 19. VIN cap
- 20. Seat
- 21. Pillion step
- 22. Rear carrier
- 23. Combination light
- 24. License plate light
- 25. Rear reflector
- 26. Air filter
- 27. Main stand
- 28. Side stand

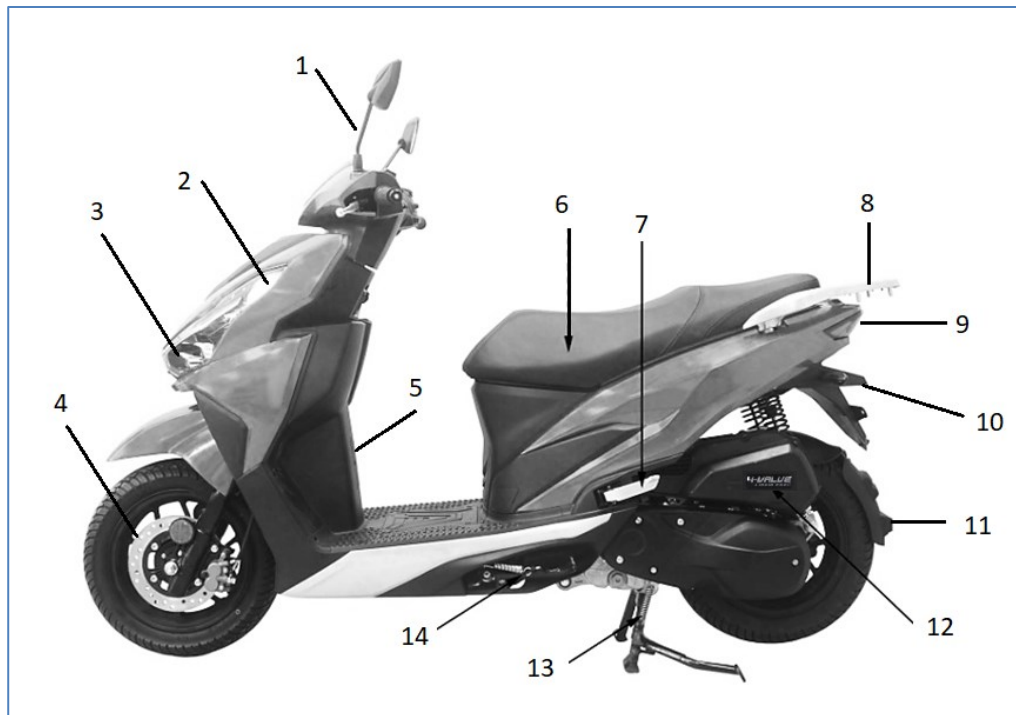

## Controls and instruments

11. Dashboard unit
12. Left grip
13. Left lever
14. Left handlebar switches
15. USB socket
16. Bag hook
17. Main switch
18. Right handlebar switches
19. Right lever
20. Throttle grip

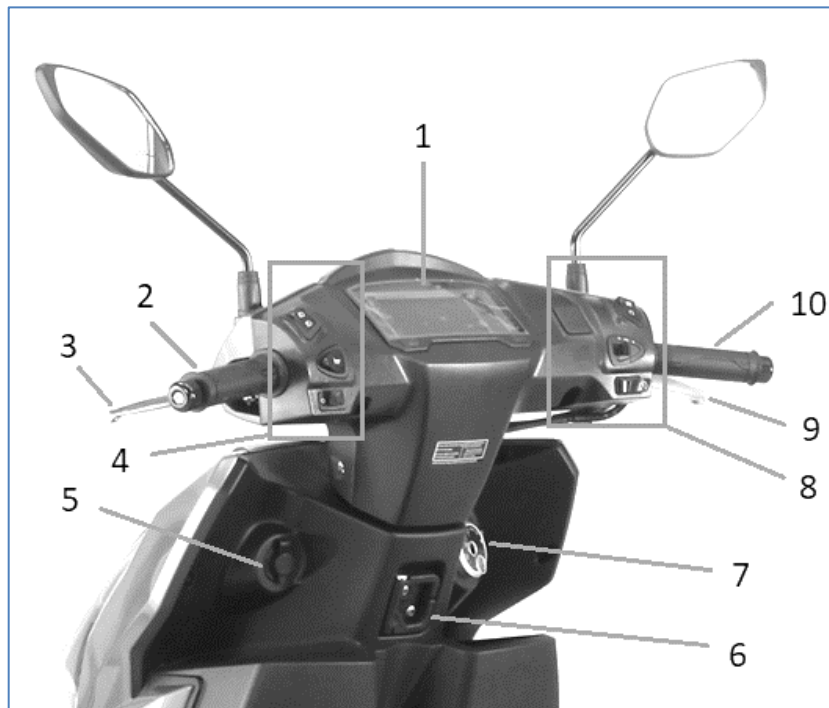

# DESCRIPTION OF THE VEHICLE

EN

## DASHBOARD UNIT



6	High beam indicator
7	ABS warning indication*
8	Hybrid indicator*
9	Water temperature alarm indicator
10	Right button (clock setting)
11	Trip counter (TRIP A/B)
12	Speedometer
13	Odometer
14	Left button (TRIP A/B reset)
15	Fuel level gauge
16	TCS indicator*
17	Start and stop indicator*
18	EFI warning indication

1	Left turn signal indicator
2	Clock display
3	Engine revolution display
4	Position light
5	Right turn signal indicator

\*Optional: For EU countries

## HANDLEBAR SWITCHES – LEFT

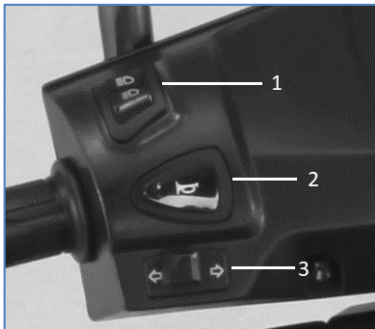



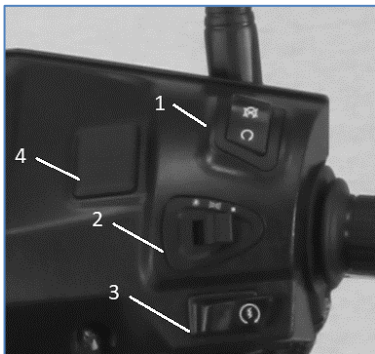

1	Low/High beam switch
2	Horn button
3	Turn signal switch

## HANDLEBAR SWITCHES - RIGHT

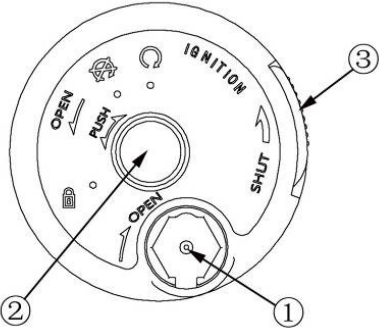
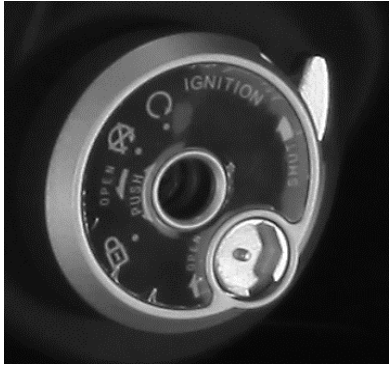
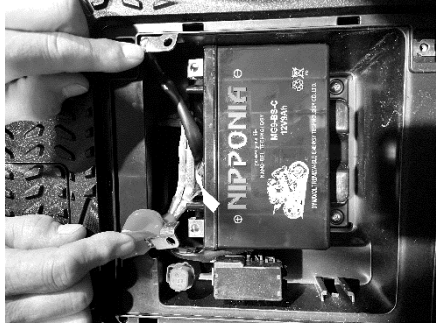

1	Emergency shutdown switch
2	Light Switch
3	Ignition switch
4	Blank button

MAIN SWITCH		Battery installation
		
<ol style="list-style-type: none"> <li>1. Ignition switch slot</li> <li>2. Keyhole cap</li> <li>3. Button</li> </ol>	<ol style="list-style-type: none"> <li>1. ON </li> <li>2. OFF </li> <li>3. Steering lock </li> </ol>	<p>Place the battery according to the above photo.</p>



**NIPPONIA CARIBE SRL.**

**a:** Calle Paseo del Arroyo, No.1, Distrito Nacional,  
Santo Domingo, República Dominicana

**e:** [ncaribe@nipponiacaribe.com](mailto:ncaribe@nipponiacaribe.com)

**t:** +1 809 3721789

**w:** [www.nipponiacaribe.com](http://www.nipponiacaribe.com)